



LN-G3-MS50

**GEN-3 HD DIGITAL TECHNOLOGY
DAY & NIGHT MONOCULAR / SCOPE
6-36x50**

INSTRUCTION MANUAL

**IMPORTANT: Please read this manual in its entirety prior
to using this device!**

DIGITAL NIGHT VISION TECHNOLOGY:

1. Your night vision viewer operates with batteries. Unlike a daylight binocular, where you see the image due to light traveling through the glass and the prisms, the digital night vision device works by projecting the image onto an OLED display screen. While the Image Sensor and the OLED display are the crucial components of your viewer, the optical parts of the unit are also very important, as they gather the light into the Image Sensor and then bring the projected image from the OLED screen to your eye. Since the image is projected on the display screen, just like any TV, it has certain limited resolution, so your digital night viewer cannot provide the same crystal clear image, as you see through your daylight binoculars.
2. **Another important point** – your digital night vision viewer has option of full-color, night vision green and black & white image – why? Because, while full-color image is an excellent choice during daylight, it sometimes washes out the details in the dark and will not be as effective as monochrome image during nighttime conditions. The night vision green color was chosen because green color shows more details than any other color in the palette and black & white image is especially useful when reading text or building signs or car plates during nighttime.
3. Your digital viewer is safe to operate during daylight and nighttime hours. **IT IS NOT SAFE FOR YOUR EYES TO LOOK DIRECTLY AT THE SUN THROUGH THIS PRODUCT!** Please note that during daylight you will have to reduce the brightness level of the unit to prevent the image from becoming totally washed out. You should also utilize Color Enhancing Filter, supplied with the unit for daylight operation in order to view more vibrant colors. (Filter is attached to the front lens and also acts as a protective lens cover)
4. For more details on how to operate your viewer, please read this manual completely to ensure proper operation.

YOUR PACKAGE INCLUDES THE FOLLOWING:

1. LN-G3-MS50 Monocular/Scope
2. Weapon Mount with 3 mounting screws and Allen Wrench Keys
3. 8GB Micro SD-card (installed into the SD-card slot)
4. Color Enhancing Filter (installed onto the front lens)
5. Carry case & Wrist Strap (strap is installed on the monocular)
6. USB Cable, HDMI cable & Micro-SD Card USB Adapter
7. 2xCR123A batteries (NON-RECHARGEABLE!)

Please identify all the parts of the device PRIOR to operation!



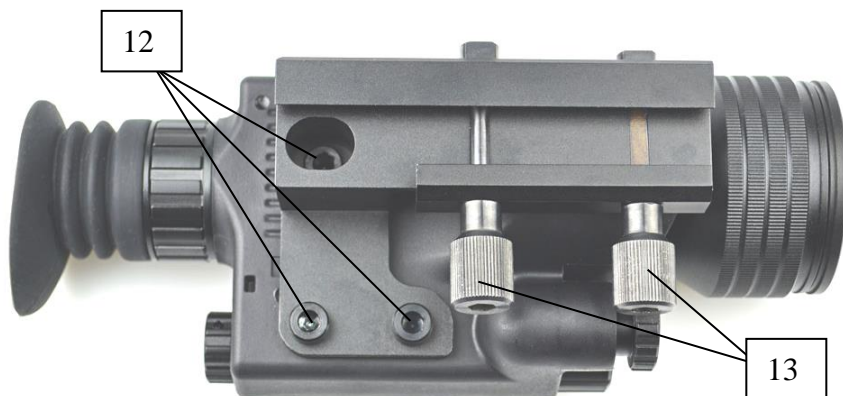

GLOSSARY:

- | | |
|--|-----------------------------------|
| 1 – Objective Lens Focusing Wheel | 9 – Menu Controller |
| 2 – IMAGE Button | 10 – Weapon Mount |
| 3 – CAMERA Button | 11 – Connection Area: |
| 4 – POWER & IR Button | 11-a) Micro-SD Card Slot |
| 5 – Ocular Focusing Wheel | 11-b) Micro-USB Connector |
| 6 – Battery Compartment Cover | 11-c) Micro-HDMI Output |
| 7 – Infrared Illuminator Lens & Barrel | 12 – Mounting screws |
| 8 – Rubber Eyecup | 13 – Weapon Mount Retainer Screws |

INSTALLING THE BATTERIES:

Your device operates on two 3V Lithium type batteries, known as CR123A type commonly available in Electronics/Camera/Convenience stores. **NOTE: it is possible to use rechargeable batteries (CR123R) but please make sure each battery peak voltage is equal to or less than 4.2V**

WARNING: batteries supplied with the unit are not rechargeable – do not try to charge these batteries!

WARNING: Use only compatible chargers with overcharge protection to charge any rechargeable CR123R batteries.

To install the batteries, unscrew the battery compartment cover (6), and install two CR123 batteries into compartment inserting the positive (+) end first. Once the batteries are inside, replace the cover by rotating it all the way to the end until the stop (cover must be replaced all the way until the rotation is no longer possible, especially when using as a riflescope but once rotation stops do not over-tighten the cap!)

DAYLIGHT COLOR ENHANCING FILTER:

Your digital viewer is equipped with a unique daytime color enhancing filter, which provides vibrant and accurate colors rendition during daytime. The filter comes attached to the objective lens and we strongly recommend keeping it on during daytime use. During nighttime you will need to remove the filter (by unscrewing it counter-clockwise).



TURNING THE UNIT ON AND OFF:

To turn the unit ON, press the POWER Button (4) momentarily once. The LED Power Indicator located on the back of the unit should light up in green color. Look through the eyecup (8) – you should see the Welcome screen for a few seconds, followed by image. Even if the image is not yet sharp, the unit is operating. To turn the unit OFF, press and hold the POWER Button for 2 seconds. The image will disappear if you turn the unit off correctly.

ON-SCREEN DISPLAY ICONS:

Video Recording Counter

Video Resolution



Camera Mode

IR Power Level

Image Magnification

Time (or Time Elapsed)

Power source

OPERATING FROM A USB POWER BANK:

Your digital viewer can also operate from the commonly available 5V USB Power Bank chargers. Please make sure the output of the Power Bank is at least 2A, as less powerful output may fail to power the unit especially when the IR illuminator is

activated. To connect the Power Bank, open the Connection Area (11) rubber cover by gently pulling it outward and then swing it counter-clockwise to the right and locate the Micro-USB connector (11-b). Connect the small end of the USB cable (included) to the connector and then connect the large end of the cable into Power Bank output. You may need to activate the power bank first, prior to turning the viewer on.

FOCUSING THE UNIT:

To obtain the sharp image, you must first rotate the Ocular (Eyepiece) Focusing Ring (5) in either direction, until you notice in which position you can see the on-screen display icons well. After that, rotate the Objective Lens Focusing Wheel (1) focusing at the object you are trying to view until the image is at its best. You may have to repeat (fine-tune) the process again, until the image is sharp and clear. Once the clear image is obtained, you will no longer need to adjust the eyepiece, just rotate the front objective lens to adjust the distance to the object you are viewing.

MENU CONTROLLER / MENU FUNCTIONS:

Your digital viewer features a unique and user-friendly adjustment called Menu Controller (9). It incorporates various operating functions and makes navigating and adjusting menu functions fast, easy and natural without having to take your eyes off the eyepiece in the field. It is especially useful when using in the dark conditions where button location may be particularly difficult. Controller activates the Main Menu by pressing onto it for approx. 2 sec.

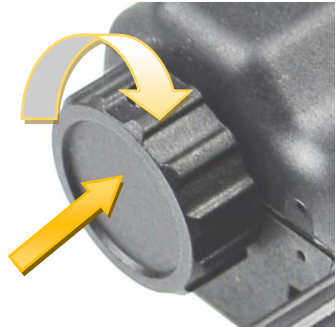

Once activated, all Menu navigation is done the following way:

- **Scrolling through the menu contents:** rotate the Controller in either direction (each click scrolls the menu by one step)
- **Selecting and confirming function:** short-press onto the Controller
- **Return from selected function to Main Menu:** Long-Press onto Controller (2 sec)
- **Exiting the Main Menu:** Long-Press onto the Controller (2 sec)

MAIN MENU consists of the following selections:

MODE:

- **Video:** this mode allows you to record videos when CAMERA button (3) is pressed during operation
- **Photo:** this mode allows you to capture still images when CAMERA button (3) is pressed during operation
- **Playback:** this mode allows you to playback videos and photos stored on your SD card

RESOLUTION:

- **FHD 1080P@30:** Video record in Full-HD (Blue-Ray quality) at 30fps
- **HD 720P@60:** Video record in HD at 60fps (preferred at nighttime)
- **HD 720P@30:** Video record in HD at 30fps
- **WVGA 480P@60:** Video record at DVD quality at 60fps

IMAGE COLOR:

IMPORTANT: IMAGE COLOR CAN BE QUICKLY SELECTED BY SHORT-PRESSING ONTO MENU CONTROLLER (9) DURING EITHER VIDEO OR PHOTO MODE

- **Normal:** Image is displayed in Full-Color (best for daytime or well-lit room – keep the red filter on the front lens during daylight, also good for nighttime sky watching)
- **B&W:** Image is monochrome black & white (perfect for nighttime city/urban setting)
- **Green:** Image is monochrome green (good for nighttime field use)
- **Amber:** Image is amber color (good for all daytime/nighttime settings and especially where light glare might be an issue or whenever extra contrast is desired)

RETICLE:

- Short-press the Menu Controller to enter the selection. Rotate the Controller to change the type of the reticle (5 choices available) – then short press the Controller to activate the reticle.

RETICLE COLOR:

- Allows to select the color of the reticle: WHITE / RED / GREEN / YELLOW / ORANGE / BLUE / BLACK

RETICLE ADJUSTMENT:

- **OFF:** press if you do not want to adjust reticle at this time to exit
 - **ON:** This mode allows to zero the reticle. The reticle will move across the screen during adjustment. Follow instructions in the addendum (ZEROING SCOPE)
 - **Saved Adjustment** Allows you to load or delete saved adjustment profiles. Follow instruction in the addendum (SELECTING RETICLE ADJUSTMENT PROFILES)
- IMPORTANT! Please read all chapters of “USING DEVICE AS RIFLESCOPE” in the included addendum for more information about reticle zeroing!**

WI-FI:

- **ON:** Turns the Wi-Fi signal ON. See page-13 for instructions
- **OFF:** Turns the Wi-Fi signal OFF

DATE/TIME:

- **Please see Page-9** on how to set the date/time on your monocular

FORMAT:

- **Cancel:** Exit formatting
- **OK:** Format your SD-card (all files will be erased!)

DEFAULT SETTINGS:

- **Cancel:** Exit to main menu
- **OK:** Returns monocular to factory settings

VERSION:

- Displays current software version installed in your device

ELECTRONIC IMAGE MAGNIFICATION ZOOM:

Your unit is also equipped with electronic zoom function, which allows you to change image magnification from 6x to 36x. To increase the image magnification rotate the Menu Controller (9) to the right (clockwise) and look into the ocular – you will see the image magnification increase with each rotation click by 3x. See below the magnification chart according to each rotation:

6.0x – 9.0x – 12.0x – 15.0x – 18.0x – 21.0x – 24.0x – 27.0x – 30.0x – 33.0x – 36.0x

You can observe the current magnification level on the bottom left corner of the image display once you start rotating the Controller. To decrease the image magnification, rotate the Controller to the left (counter-clockwise) and image magnification will decrease by 3x with each rotation. Factory default setting is 6x

NOTE: During any image magnification adjustments, please avoid pressing onto the Controller, as this may activate the device main menu.

SHORTCUTS (MULTIPLE BUTTON FUNCTIONS):

The three top buttons can be used to skip the main menu navigation and provide quick shortcuts to the most popular functions:

POWER & IR BUTTON (4):

- Initial short-press – turns the power ON
- When power is ON, single short press activates 1st power level of IR illuminator. There are 3 IR power levels – each consecutive short-press increases the power by one level. 4th short-press turns the IR illuminator OFF
- When power is ON, long-press shuts the power OFF



CAMERA BUTTON (3)

- Factory default setting is VIDEO. Short-press activates video recording
- Long-press activates Mode selection. Once activated each single long-press selects between VIDEO / PHOTO / PLAYBACK modes
- Once selection is changed single short-press on this button will either activate Video recording, Still Image capture or Playback function

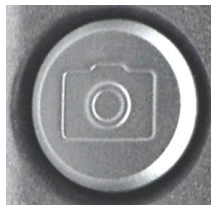
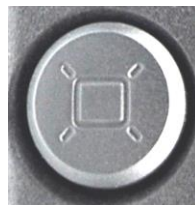

IMAGE BUTTON (2)

- a) OLED display brightness. Each short-press increases the display brightness by one level. There are 7 brightness levels and the factory default setting is level-2. See page-11 for more image brightness adjustment information



SETTING UP DATE AND TIME:

As your viewer has capability to take images and record video, time and date is automatically stamped onto each image and video recording. To set the correct date and time, please follow this procedure:

Turn the unit ON. After image appears, press onto the Controller (9) and hold it for approximately 2 seconds to activate the menu. Scroll until Date/Time function by rotating the Controller and select it by momentarily pressing onto it. To adjust the numbers, rotate the Controller in either direction. To switch between numbers, press onto Controller momentarily. After Date is set, adjust the time. Time is in 24hr format, so 13:00 is 1pm; 17:30 is 5:30pm and so on. As with the date, changing hours and minutes is done by rotating the Controller and moving between hours and minutes is done by pressing onto it. Once the time is adjusted you may choose to change the date format to MM/DD/YYYY or YYYY/MM/DD according to your preference. Once you are finished setting date and time, you can exit the menu by pressing Controller (9) for approximately 2 seconds. Once set, the time will be displayed on the bottom of the OLED image display.

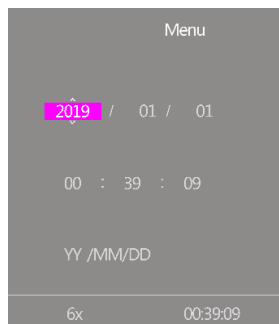

IMPORTANT: in order to preserve the set date/time do not remove the dead batteries from the unit until you are ready to replace them with the new set, then replace the old batteries with new set as quickly as possible and the date/time will be preserved.

USING INFRARED ILLUMINATOR:

Your digital viewer is equipped with a built-in powerful Infrared illuminator light (7). This light operates in a spectrum, which is normally invisible to a human eye, however with the help of the Image Sensor, located inside the unit, you will see a beam of light when looking through the ocular lens. Since the Image Sensor does not actively amplify the available light, you will need to utilize the IR illuminator often in the nighttime conditions.



WARNING: Your IR illuminator is a Class-3R laser product. NEVER LOOK DIRECTLY INTO THE IR ILLUMINATOR LENS WHILE THE ILLUMINATOR IS ON!

To turn the Infrared illuminator ON, press the Infrared illuminator button (4) momentarily – the IR icon on the bottom of the display will light in pink color and red LED light indicator (10) located next to the eyepiece will light on, indicating the IR illuminator is operating. The illuminator intensity can be further increased by pressing the IR button (4) second and third time (momentarily). The IR icon in the image display will change colors from pink to orange to red, indicating the three different power levels. After the red level (3rd and most powerful) the next momentary press on the IR button will turn the IR off completely. The red LED light indicator (10) will disappear when the IR illuminator is properly turned off.

When using the infrared illuminator it is important to remember that like a flashlight, it is brightest when used in short distances. As the distance increases, the intensity of the infrared light fades away. The illuminator lens can be focused by rotating the front lens barrel (7). This allows for the IR beam to be widened (shorter effective distance) or narrowed (longer effective distance).

Accessory IR illuminators are available (models LN-EIR850-2, LN-EIR940-2 or LN-ELIR-2), which can be mounted into the single (black) bottom accessory mount socket. The thread is a standard ¼" type and will accept any accessory with mounting screw of that size. If the black bottom mount is utilized for tripod mounting, you can utilize any of the two gold sockets. Please note that due to the monocular shape a special riser plate will be required to mount our illuminator (please e-mail us at info@lunaoptics.com and request this riser plate if your extended range illuminator did not come with it).

IMAGE COLOR OPTIONS:

IMAGE COLOR CAN BE QUICKLY CHANGED BY MOMENTARY PRESS ONTO MENU CONTROLLER

- **Normal mode** displays images in full-color. This is preferred mode for daytime use as well as when enough artificial light is present (inside a well-lit room). If used during nighttime the overall sensitivity of the image sensor will be significantly reduced.
- **B&W mode** displays images in black and white. This mode is particularly useful during nighttime city setting when it might be important to read the street signs or automobile plates or similar situations where highest contrast between light and dark colors is necessary.
- **Green mode** allows you to experience image as seen with traditional "tube" night vision devices. This mode is best utilized at nighttime in the field / forest settings
- **Amber mode** unique state-of-the-art color minimizes incoming light glare and provides extra contrast allowing to perfectly see the smallest details. Excellent for nighttime settings, but is also very useful in daylight during both: bright sunshine or cloudy days where extra contrast is desired

IMPORTANT: PLEASE READ!

Due to the inherited limitations of any digital image sensor, video refresh rate will be significantly slower during nighttime, resulting in visible image lag/delay when using your monocular in the dark. It is important to take the following steps to minimize this effect and ensure the best possible image and video recording quality:

- During nighttime and in any dark condition always activate built-in IR illuminator – it will provide extra light needed for the image sensor to “speed up” its refresh rate and image delay will be minimized.
- During nighttime you need to remove the daylight color enhancing filter – it will block most of the Infrared light from the built-in IR illuminator resulting in very dark image.
- Always try to utilize a quality tripod for any video recording done at nighttime. This will ensure steady placement and will minimize image delay when filming a moving object.

BRIGHTNESS ADJUSTMENT:

Your digital viewer is equipped with dual image brightness control. An automatic picture optimization sensor adjusts the image according to the available ambient and artificial light. In addition a manual Image Brightness Button (2) allows you to fine-tune the image brightness to the most comfortable level. Please note that during daylight you will need to tone the brightness down to avoid image flickering and/or washout and to preserve the battery life. During nighttime you could increase the brightness all the way up, however when utilizing built-in or external IR illuminator, you may still need to tone the brightness down. Each momentary press onto the IMAGE Button (2) will increase brightness by one level until it reaches maximum level – then it will reset to the lowest brightness setting.

TAKING PICTURES AND RECORDING VIDEOS:

Your digital viewer has the ability to take High-Resolution pictures and record HD videos onto the external Micro-SD card. 8GB card is included with your unit and it is already installed into the SD-card slot. The Micro-SD card can be upgraded up to 128GB, which is especially useful if you plan to record a lot of videos **See RE-FORMATTING 64 & 128GB CARDS TO FAT32 FORMAT on page-14 for important instructions.**

Your monocular has a multi-use CAMERA button (3). It can be used to record video and capture still images. You can switch the function of this CAMERA button by activating the Main Menu (long press onto Super Controller (9)) and selecting Mode function and then select either Video for video recording or Photo for still image capture. **Please refer to Page-6 for instructions on how to use Super Controller and Menu options.**

To take a still image, focus the unit onto the object you are viewing and with a steady hand firmly press the CAMERA button (3) once. The display will give a

countdown (2-1) in the upper left corner and then image is taken and is automatically stored onto the SD card. All still images are taken at 4032x3024 resolution (12.2MP)

To record a video, focus the unit onto the object and press CAMERA button (3) once. The system will start recording. To stop recording, press CAMERA button once again. During recording it is still necessary to re-adjust the focus if you wish to record different objects, located at different distances. There are 4 different video recording resolution options:

1. FULL-HD 1080P / 30FPS: Blue-Ray quality recording. Best for recording in daylight with color filter on when highest video resolution is necessary. Also good for recording at nighttime without the color filter, when monocular is stationary on a tripod and no sudden movements are expected
2. HD 720P / 60FPS: Excellent for daytime and nighttime recording.
3. HD 720P / 30FPS: Daytime and nighttime recording.
4. WVGA 480P / 60FPS: DVD quality recording, great for space saving mode where large amount of video is expected

IMPORTANT: once your micro-SD card reaches its capacity, video recording and still image taking will no longer be possible and “SD Card” will be displayed, indicating it is time to either replace the card or empty your current card. This feature acts as a safeguard to prevent accidental over-writing your existing video and photo files.

IMPORTANT: If you see “Memory Error” message displayed, your micro-SD card is either bad, or, if you have a 64GB or 128GB card, it is not operating in FAT32 format. Please refer to page-14 for re-formatting instructions.

DATA VIEWING AND DATA TRANSFER OPTIONS:

It is possible to view the images and videos directly on the unit’s micro-display. To do so, while the unit is operating access the main menu by pressing the Menu Controller for 2 seconds. Enter “Mode” menu and choose “Playback”. As always, scrolling between functions is done by rotating the Controller and function selection is done by short-pressing the Controller. Once in the Playback Mode you will be able to switch between photos and videos by rotating the Super Controller and short-pressing Controller will activate any video file. To exit the Playback Mode simply press Controller for 2 seconds.

You can connect the unit directly to the computer via USB connection by utilizing the micro-USB connector (11-b). To do so, connect the micro-USB part to the unit, then connect the standard USB part to the computer. Device does not need to be powered. It will power up once connected. Look through the eyepiece – words **MASS STORAGE** will be displayed. Connection will start automatically once the

software download is finished (also done automatically). Once download is done, you will be able to open and transfer all of your SD-card files onto your computer.

Alternatively, you can remove the micro-SD card from the monocular and use it in the included USB flash drive adapter to transfer data to your computer. Carefully open the Connection Area (11) rubber cover by gently pulling it from the left side outward and then swing it counterclockwise to the right and locate the Micro-SD Card Slot (11-a). Gently push onto the micro-SD card and it will pop out. If your computer has a direct micro-SD slot, you can insert the card directly to the slot bypassing the above options. It is also possible to utilize the full-size SD card adapter (not included with monocular). To replace the micro-SD card gently push it into the slot (11-a) until it clicks and stays in it.

CONNECTING TO EXTERNAL VIDEO SOURCE:

You can connect your device to the HD source, such as HDTV or monitor via the micro-HDMI cable (included with your device). Carefully open the Connection Area (11) rubber cover by gently pulling it from the left side outward and then swing it counterclockwise to the right and locate the Micro-HDMI output (11-c) Connect the small end of the cable to the micro-HDMI Output and then connect the large end of the cable to the HDMI input on your TV or monitor.

IMPORTANT: Please note that when device is connected via HDMI to any video monitor or HDTV, it will be impossible to connect via Wi-Fi to the App during active video recording. If you wish to connect to the Wi-Fi App, you will need to discontinue video recording.

WI-FI LINK AND OPERATION INSTRUCTIONS:

1. Download “**ROADCAM**” App on your Android phone/tablet or on iPhone/iPad. For Android users if you have a problem finding the app in Google Play Store, please scan the QR code below
2. Enter Main Menu via Super Controller (9) and scroll to Wi-Fi selection. Turn the Wi-Fi ON. Now look through the eyepiece and observe the Wi-Fi signal name (typically **M5**) and Password (typically **12345678**).
3. Find the device Wi-Fi signal on your phone (same as shown on the unit’s display) and select it.
4. Enter password (second line of the unit’s OLED display) – **NOTE: only numbers after “:” are needed to be entered – typical default password is 12345678.**



5. **Once connected make sure your phone is allowed to stay connected to this Wi-Fi signal even though there is no internet available.** This will prevent automatic disconnect by your phone.
6. Now open the app and it will display the device name below the orange cam symbol – simply touch the cam symbol and app will connect to the device.
7. Follow on screen menu on your smart device to utilize the available features of the app. NOTE: during Wi-Fi streaming the ZOOM function is disabled and cannot be utilized!
8. During Wi-Fi streaming single press onto the Super Controller activates either Video or Photo capture, depending on the selected mode. Repeat press deactivates video.
9. If the App shuts down during normal use, please re-start it, or re-install it on your mobile device if it happens more than twice.

RE-FORMATting 64GB & 128GB MICRO-SD CARDS TO FAT32 FORMAT:

Any micro-SD card above 32GB needs to be re-formatted from EXFAT format to FAT32 format, which is the format of the night vision monocular (and many other consumer electronics). Please note that FAT32 is the most widely used format and is also considered the most reliable format.

In order to re-format the card you must run it through a 3rd party provider. We suggest using Disk Partition. While nearly all of the providers would want you to buy their upgraded versions, you can just download their basic free version and it would be sufficient to re-format the card. Disk Partition seems to be the most simple and hassle-free provider we could find:

<https://www.disk-partition.com/download.html>

- Download the “Standard Free” version and follow all the download instructions.
- Once downloaded, open the program and insert the micro-SD card into the computer.
- Highlight the correct disc by single-click and then choose on the bottom left side of the menu to “Format Partition” (alternatively right-click on the highlighted disc and choose the same function). A pop-up window will appear. You can label your partition (such as “Luna Optics Monocular” or any other name you desire (it’s optional) and then make sure to select “FAT32” as the File System. Then click “OK”.
- Once the format is finished, click on “Apply” located in the most upper left corner. You must select “Apply” otherwise the formatting is not finished.
- Your card is now formatted, but before you can use your 64/128GB card in our digital night vision product you must also format the card inside the

product. To do so, insert the card into its slot (11-c), turn your monocular on and through the menu find and select “Format”, then select “OK”. Once the card is formatted inside the device it is now ready to use.

USING DEVICE AS A RIFLESCOPE:

IMPORTANT:

Your monocular can function as a riflescope. Prior to using the scope on the weapon, please remember the following:

1. This item was designed for use on the following calibers only:
 - Airsoft guns
 - BB and Pellet guns
 - Most rimfire caliber weapons (.17WMR; .22LR; .22WSM and other rimfire cartridges)
 - Centerfire calibers **limited to** .223REM; 5.45x39 (AK74 round) and similar with total recoil energy of 4.5 or lower. **DO NOT USE THIS DEVICE WITH ANY CALIBER WITH RECOIL ENERGY OF OVER 4.5**
2. Know and observe all Federal, State and Local laws, regulations and restrictions concerning possession and use of daylight and/or night vision riflescopes. Luna Optics Inc cannot be held liable for unlawful and/or unauthorized possession or use of this device.

ACTIVATING RETICLE / CHOOSING RETICLE TYPE AND ITS COLOR

Your device ships from the factory with default mode where aiming mark (reticle) is not visible. To activate the reticle go to the main menu and scroll until “Reticle” and then short-press the Super Controller to enter this menu chapter. You will see the factory default reticle. Now you can rotate the Super Controller in either direction to select the type of reticle (there are 5 types available). Once you select the preferred reticle type short-press Super Controller and you will exit the menu. The selected reticle will now be visible on the screen.

Once the reticle is activated you may now select its color. There are 7 colors available. Once selected the color you like simply short-press the Super Controller and you will exit the menu and the reticle will be displayed in selected color.

ATTACHING DEVICE TO THE WEAPON

Your monocular can be attached to any standard Picatinny Rail via the included weapon mount (10). **NOTE:** mount design may be slightly different from the one pictured, as updates are constantly made to improve its function.

- First, attach the mount to the bottom of the monocular, using the 3 screws (12) as shown on picture here. If you plan to use the device as a

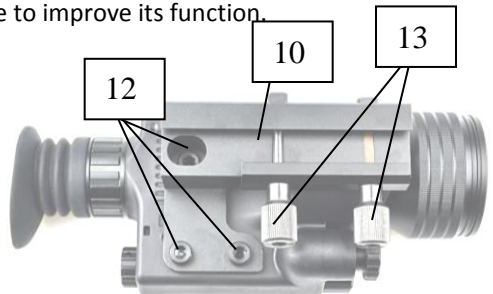

riflescope for an extended period of time, put a small drop of Loctite 242 (Blue) on the screws' threads prior to attaching the mount to the monocular. This will prevent the screws from becoming loose over time.

Do not use Loctite Red or similar permanent solutions!

- Once the mount is securely attached to the monocular housing, loosen the Retainer Screws (13) to the point where mount can easily go over the Picatinny rail and clamp over on the other side and attach the scope on your weapon, as you would any riflescope, allowing for the proper eye-relief. Do not tighten the Retainer Screws all the way until proper and comfortable eye-relief is set. **NOTE:** the scope has a suction cup type eyepiece, which helps to protect your eye from any effect of recoil, so it is necessary to install the scope at such distance where your eye is touching the outer rim of the rubber eyecup during weapon shouldering and aiming.



- Once the correct placement is chosen, secure the scope on the rail by tightening the Retainer Screws.

- Please pay attention to the Retaining screws back-end tips making sure they are seated fully in the side groove of the mount (as shown on the picture here).

Now tighten the retainer screws. If necessary use a small Allen



wrench key by inserting it into Retainer Screws small holes which will give you extra rotational strength to tighten the screws. Once rotation is no longer possible STOP – do not over-tighten! If you plan to use this scope on the particular rifle for a long time or permanently add a small drop of

Loctite 242 (Blue) on the Retainer Screws threads, which will prevent them from becoming loose over time.

Your scope is now ready to be sighted (zeroed).

ZEROING THE SCOPE

Prior to any adjustment you must secure your rifle in a vice or similar position where it cannot be easily moved.

IMPORTANT: make sure that once the reticle adjustment process starts, your weapon is not physically moved until the process is over. Once rifle is secure, go through the following process step by step – do not skip any steps or jump through the steps:

1. Go to the main menu via the Menu Controller and select **RETICLE ADJUSTMENT** and then select **On**
2. Next screen will feature an area with yellow borders, which represent the maximum reticle adjustment area. Reticle can be moved anywhere within the border area.
3. Place the initial shot while aiming your reticle at the bulls-eye of the target. Observe the actual location of the target where bullet went through. **Do not move your rifle.**
4. You now need to move the reticle from its current position to the actual bullet impact position. To do that make sure the reticle is still aimed directly at the bullseye and then short press the Menu Controller button to freeze the image. Once the image is frozen, the small green “x” will appear in the middle of the reticle and **X=0 / Y=0** values will be visible to the right side of the yellow box. X = represents the horizontal (windage) adjustment and Y = represents the vertical (elevation) adjustment. By default letter **X** will be highlighted in red color first, meaning the horizontal movement is ready for adjustment. Move the reticle by rotating the Menu Controller wheel either clockwise or counterclockwise, depending on which direction you need to move the reticle, until green “x” is located directly under or over the bullet impact hole. Now short-press the Menu Controller and letter “**Y**” will become highlighted in red color meaning you can now adjust the vertical movement of the reticle. Rotate the Menu Controller until the green “x” is positioned exactly over the bullet hole. If the small green “x” is at the exact point of the bullet impact, then proceed to the next step by short-pressing the Menu Controller once more to highlight in red “**P1**” in the upper right corner of the screen and proceed to step-5. If further reticle adjustment is still needed then short-press the Menu Controller again to highlight either “**X**” or “**Y**” in red and make further adjustments in the same manner as described above
5. When **P1** is highlighted in red you are ready to save the adjustment in the system. **P1** stands for “Profile 1”. To save the profile make sure **P1**

is highlighted in red and then press the Menu Controller for 2 seconds. The profile will be saved and reticle will now appear in the new position on the screen (position where you moved it during adjustment).

6. At this time you can take follow up shots aiming at the bullseye of the target and make sure that bullet impact is within acceptable distance from the bullseye. If the bullet impact is still not on the target, you can repeat the zeroing process again and when saving as the same profile (**P1**) the system will ask if it is OK to change the initial adjustment – select **OK** and the new adjustment will be saved under the same profile.

There are total of 5 profiles, (**P1, P2, P3, P4** and **P5**) which can be saved independently and then loaded from the menu. This allows you to zero the scope for either up to 5 different weapons, or at 5 different distances or for up to 5 different calibers/bullet types (or any combination thereof). To switch between different profiles during adjustment rotate the Menu Controller and observe the Profile number in the upper right corner of the display.

SELECTING RETICLE ADJUSTMENT PROFILES

Once the reticle profile is saved it stays saved unless you choose to replace it during a new adjustment, or return to factory settings by selecting Default Settings from the main menu. **Do not select Default Settings if you wish to keep your reticle profile settings!**

To select (load) a reticle adjustment setting (profile), activate main menu, then select **RETICLE ADJUSTMENT**, then select **Saved Adjustment**, then select which Profile number you wish to load and then select **load**. If you wish to delete the profile, instead of loading it, select **delete** at this time.

RETICLE AND SCOPE USE SPECIFICS

Please note and remember the following specifics of using this particular device as a riflescope:

- Since this device is not a dedicated riflescope, the reticle will not be visible during video recording playback.
- This device was originally designed as a handheld monocular and is therefore not suitable for any caliber with recoil energy above 4.5. It includes most 5.56NATO cartridges, which have higher recoil energy than the civilian .223REM caliber. Therefore, if you are using this device as a riflescope on an AR-15 platform or on a bolt-action rifle that accepts not only

.223REM round, but also 5.56NATO round, please avoid using 5.56NATO round while this device is mounted on the weapon.

TROUBLESHOOTING:

1. Unit does not turn on and the light indicator is off:
 - a) please check if the batteries are inserted correctly
 - b) please make sure the batteries are fresh
2. The light indicator is working, but you cannot see the image:

You may be turning the unit on in a dark area without utilizing the IR illuminator. Please also remove the Daytime Color Filter.
3. Unable to obtain sharp and clear image:
 - a) you may need to repeat the process of rotating the ocular and objective lens several times until you get a good feel of it
 - b) You may be viewing an object that is too close – the minimum focusing distance is approximately 80cm or 2.6ft
4. During image magnification adjustment color suddenly changes or Main Menu activates:

You have accidentally pressed onto the Super Controller either momentarily (color change) or for more than 1sec (Menu activation). Press onto it again for approximately 2 seconds and Menu will disappear.
5. I'm trying to turn the IR illuminator on and instead the unit shuts down:

You are holding the Power/IR button for more than 1 sec. In order to turn the IR illuminator on, you must press the button only momentarily.
6. I'd like to use a 64GB or a 128GB micro-SD card, but it's not working or is not recognized:

Your 64GB or 128GB micro-SD card must be re-formatted to FAT32 format. Please refer to page-14 for re-formatting instructions

WARNING! NEVER ATTEMPT THE FOLLOWING:

- **NEVER try to disassemble the unit by yourself or by anyone who is not our authorized technician. Doing so may result in injury and will void any warranty claims**
- **NEVER charge batteries included with the unit – they are not rechargeable!**
- **NEVER submerge the unit into water or use it during heavy rain.**
- **NEVER look directly at the sun through this device.**

- **NEVER** look directly at the IR illuminator lens while the illuminator is active.
- **NEVER** use this product as a riflescope on ANY caliber with recoil energy above 4.5

TECHNICAL SPECIFICATIONS:

Image Sensor Resolution / Sensitivity: _____ Full-HD 1920x1080 / 0.005lux
 Image Display: _____ 0.38" HD AMOLED-Q 1280x720
 Still Image resolution _____ 4032x3024 (12.2MP) JPEG
 Video resolution (signal) _____ Full-HD 1080p AVI
 Video Recording options _____ 1080p / 720p / WVGA / VGA
 Image Magnification _____ 6x-36x
 Objective Lens _____ F1.0/50mm
 Focusing Distance _____ 80cm (2.6ft) - ∞
 Viewing Distance (daylight, 6x) _____ 1000m (1090yds)
 Viewing Distance (IR complete darkness) _____ 400m (436yds)
 Field Of View _____ 9°
 Memory _____ Micro SD card (up to 128GB)
 Wi-Fi _____ Android/iOS
 Battery Power _____ 2 x 3V Lithium (CR123)
 External Power _____ 5V/2A micro-USB
 Operating Time (battery power) _____ 3-3.5hrs
 External outputs _____ micro-HDMI / micro-USB
 Dimensions _____ 170mm x 80mm x 63mm (6.7"x3.1"x2.5")
 Weight _____ 510g (17 Oz)
 Warranty _____ 1yr

LUNA OPTICS, INC. 300 Hawthorn Dr., Fate, TX 75087 (USA)

E-mail: info@lunaoptics.com Web: www.lunaoptics.com

© 2021